

科技 . 環保 . 創新
Science and technology, environmental protection, innovation.



光星機械股份有限公司

KUANG HSING MACHINERY CO., LTD.



化工食品製藥葉瓣形輪 Rotary Lobe Pumps
Chemical industry / food industry / production of drugs the Rotary Lobe Pumps



〈歷史沿革〉
History

公司簡介 Company profile

科技 · 環保 · 創新
Science and technology, environmental protection, innovation.

1970 年創立於台灣省台南市

1970 Founded in Tainan City, Taiwan Province

1971 年擴廠搬遷至台灣省台南市

1971 Moved to Tainan YongKang District Taiwan

1971 年生產外轉式齒輪泵

1971 Production external rotary gear pump

1978 年開發內轉式齒輪泵

1978 Development of internal rotary gear pump

1985 年擴大生產規模，增設鍋爐生產線，生產各類鍋爐

1985 Expand production scale · Additional boiler production line · Production of various types of boiler

1993 年開發葉瓣形輪Rotary Lobe Pumps齒輪泵浦

1993 Development lobe-shaped wheel Rotary Lobe Pumps

1995 年在廣東省深圳市設立經銷辦事處

1995 Shenzhen City, Guangdong province to set up distribution offices

1999 年投資245萬美元設立尚億新型鍋爐(江陰)有限公司
(佔地面積一萬四千平方公尺)

1999 Invest \$ 2.45 million to establish shangyi new boiler (Jiangyin) Co., Ltd. (Covers an area of fourteen thousand square meters)

2003 年尚億鍋爐取得中國C級鍋爐製造許可證

2003 Shangyi boiler made in China C-class boiler manufacturing license

2007 年尚億鍋爐增建廠房並取得中國B級鍋爐製造許可證

(目前產品：貫流式鍋爐、臥式煙管式鍋爐及熱媒鍋爐)

2007 Shangyi boiler build factories and has made China B class boiler manufacturing license

(Product: tubular boiler, horizontal smoke tube boiler and hot coal boiler)

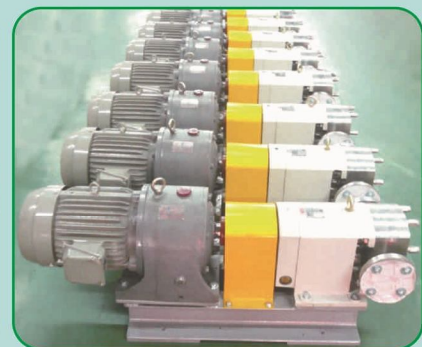
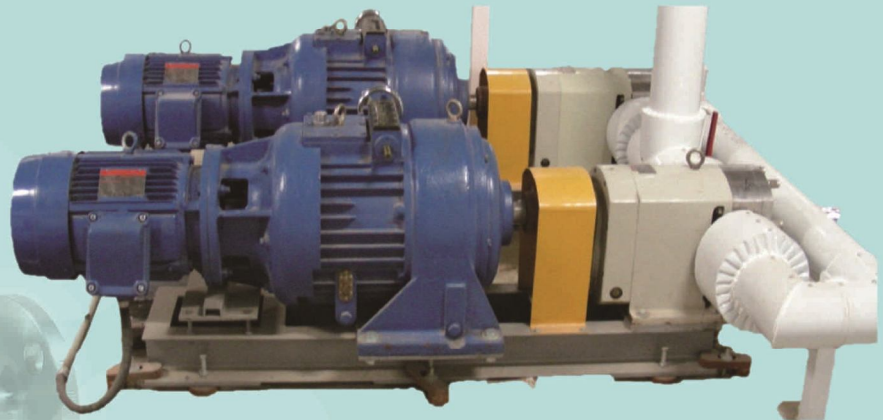

Rotary Lobe Pumps

RL-3系列泵浦規格表

RL-3 series pump specification sheet

| 泵型式TYPE | 口徑BORE | 流量/100R. P. M | 出口壓力kg/cm ² | 最高R. P. M | 參考馬力HP | 溫度°C |
|---------|----------|---------------|------------------------|-----------|--------|---------|
| RL-301 | 1" (25) | 8.0 | 10 | 900 | 2-3 | 0-200°C |
| RL-301 | 1" (25) | 13 | 7 | 900 | 2-3 | 0-200°C |
| RL-301 | 1" (25) | 16 | 4 | 900 | 2-3 | 0-200°C |
| RL-302 | 1½" (40) | 26 | 10 | 700 | 3-5 | 0-200°C |
| RL-302 | 1½" (40) | 33 | 7 | 700 | 3-5 | 0-200°C |
| RL-302 | 1½" (40) | 40 | 4 | 700 | 3-5 | 0-200°C |
| RL-303 | 2" (50) | 45 | 10 | 600 | 3-7½ | 0-200°C |
| RL-303 | 2" (50) | 55 | 7 | 600 | 3-7½ | 0-200°C |
| RL-303 | 2" (50) | 67 | 4 | 600 | 3-7½ | 0-200°C |
| RL-303L | 2" (50) | 65 | 10 | 550 | 5-7½ | 0-200°C |
| RL-303L | 2" (50) | 80 | 7 | 550 | 5-7½ | 0-200°C |
| RL-303L | 2" (50) | 96 | 4 | 550 | 5-7½ | 0-200°C |
| RL-304 | 3" (80) | 80 | 10 | 550 | 7½-10 | 0-200°C |
| RL-304 | 3" (80) | 115 | 7 | 550 | 7½-10 | 0-200°C |
| RL-304 | 3" (80) | 160 | 4 | 550 | 7½-10 | 0-200°C |
| RL-305 | 4" (100) | 240 | 10 | 500 | 10-15 | 0-200°C |
| RL-305 | 4" (100) | 280 | 7 | 500 | 10-15 | 0-200°C |
| RL-305 | 4" (100) | 300 | 4 | 500 | 10-15 | 0-200°C |

光星Rotary Lobe Pumps性能曲線圖
RL-3 performance curve

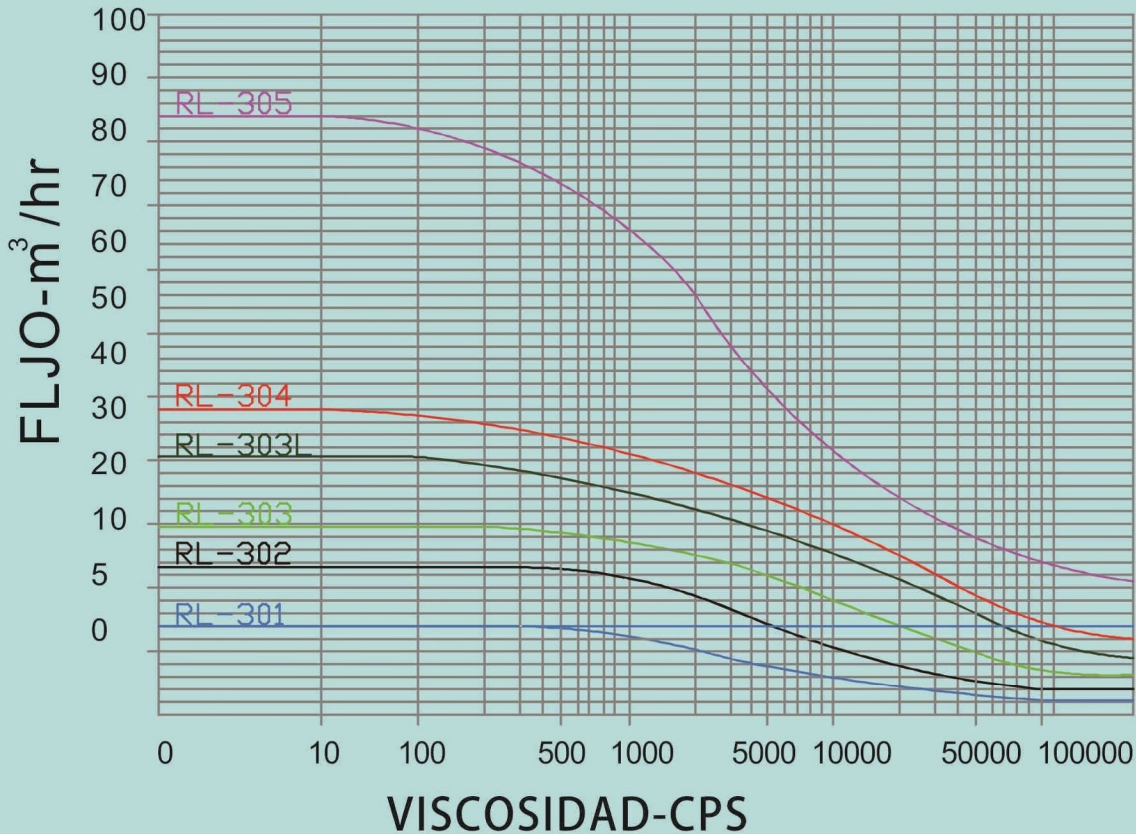



BY Pass洩壓回流安全閥

BY Pass Pressure relief valve reflux

科技 . 環保 . 創新

特性：穩定泵浦出口壓力，可自由的調整設定壓力。內裝自動回流裝置，可保持現場工作所需要之壓力；確保泵浦運轉輸送時不超壓，大大降低泵浦損耗率。

Characteristic: Stable pump outlet pressure, Can freely adjust the set pressure, Built-in automatic return means, To keep the pressure on site work, Make sure the pump is not operating over pressure, Greatly reduce the pumping loss rate

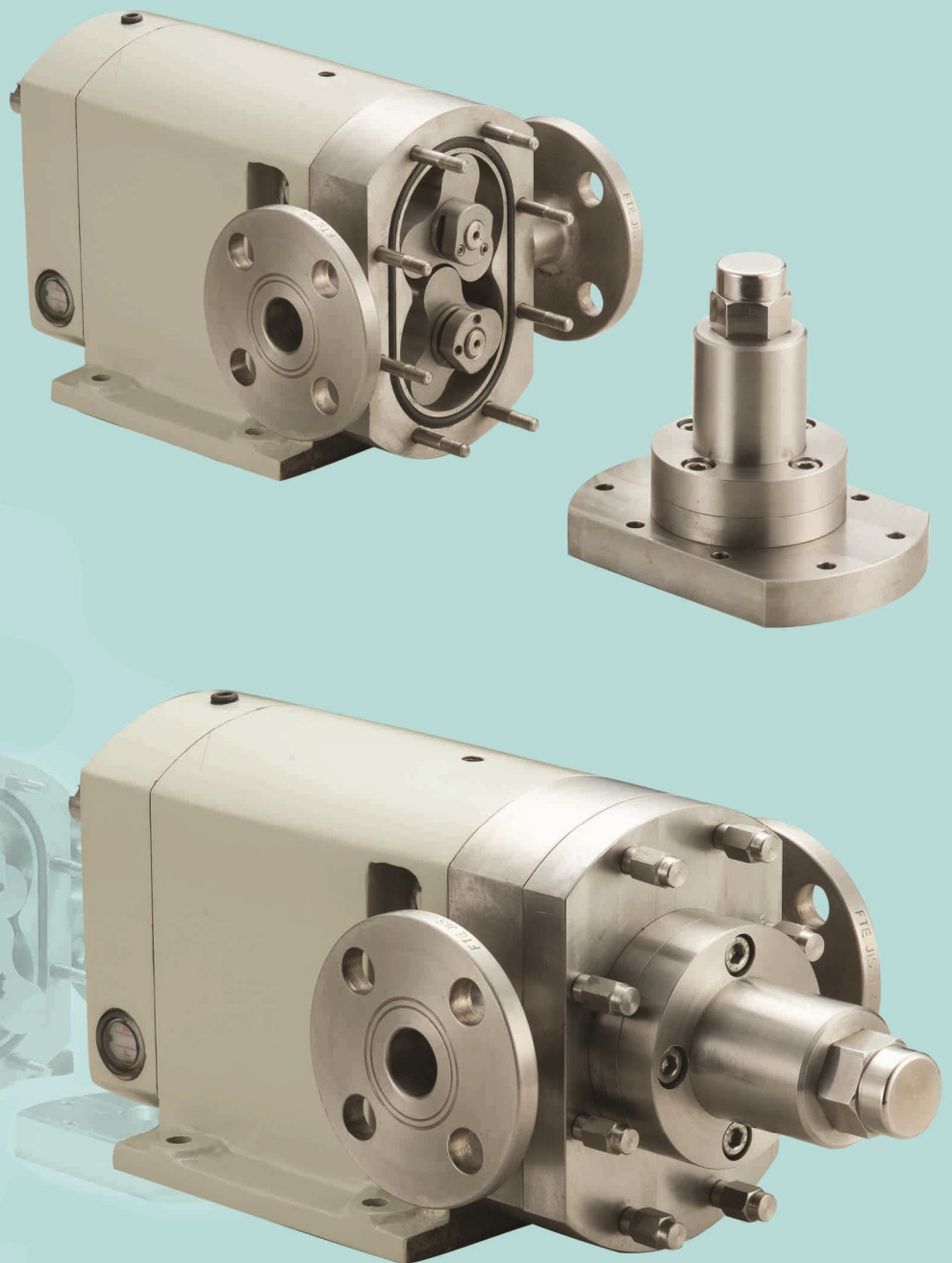

Rotary Lobe Pumps

化工食品製藥葉瓣形輪

Rotary Lobe Pumps

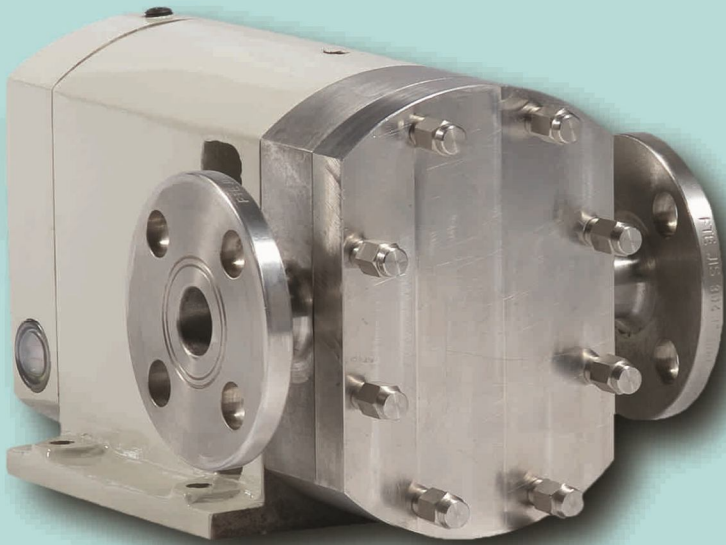

化工專用 Chemical-specific

樹脂、膠黏劑、油漆、塗料、染料、乳膠、濾土及各類高粘度液體石化工業、重油、潤滑油等用途。
(安靜無聲、拆裝清洗容易)

Resins, adhesives, paints, coatings, dyes, latex, earth and all kinds of high viscosity liquid petrochemical industry, heavy oil, lubricating oil and other purpose. (Quiet and silent, easy disassembly cleaning)

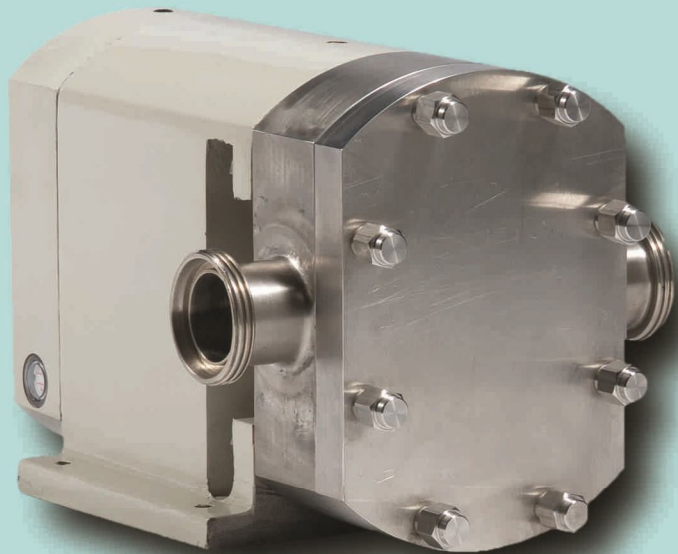

食品 Food

果醬、巧克力醬、果汁、牛奶、乳酪、布丁、啤酒

Jam, chocolate sauce, juice, milk, cheese, pudding, beer

製藥用途 Pharmaceutical use

乳霜、化妝水、洗髮精、牙膏。(安靜無聲、拆裝清洗容易)

Cream, lotion, shampoo, toothpaste
(Quiet and silent, easy disassembly cleaning)



瓣形輪系列

Rotary Lobe Pumps series

科技 · 環保 · 創新

三葉瓣形輪

Three leaf type Rotary Lobe Pumps

非摩擦式三葉瓣形輪(用途：化工、食品類等...)。
適用於高低黏度(參考值500000~1000000CPS)均可使用。
Non friction type Three leaf type Rotary Lobe Pumps。
(Uses: chemical, food, etc.)

Applicable to high and low viscosity
(reference value of 500000 ~ 1000000S) can be used

特點：

流量穩定，如化工液體內含有纖細圓形固含物以及食品類
水果顆粒等...均不損壞泵腔及葉瓣形輪。

(本公司獨特設計化工、食品專用葉瓣形輪)輸送時安靜無
噪音、堅固耐用，均配備各類液體專用機械軸封，運轉使
用時無洩漏之虞；特別是輸送化工樹脂、膠粘劑及油漆類
等...均可安心使用。

Feature :

Flow stability , Such as those containing fine solids in the liquid
chemical composition and Food fruit particles, etc.....

Do not damage the pump body and lobe-shaped wheel .

(The company's unique design of chemical, food dedicated lobe-
shaped wheel) Quiet no noise when transporting 、strong and sturdy
、equipped with various types of liquid special mechanical seal ,

No leakage in operation , Especially the transport of chemical resins,
adhesives and paints etc..... Can be at ease to use .

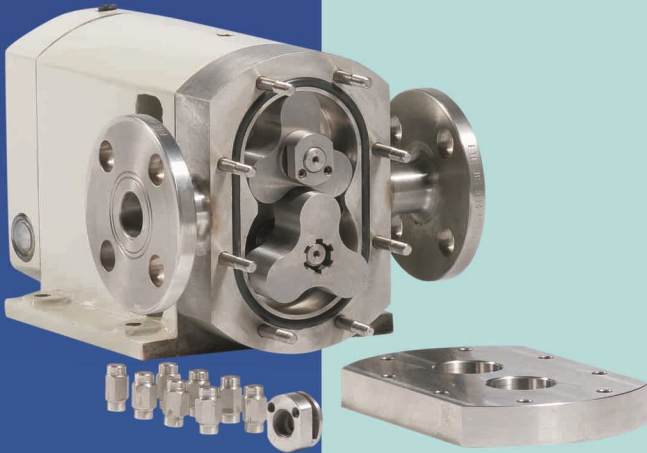

二葉瓣形輪

Two leaf type Rotary Lobe Pumps

非摩擦式二葉瓣形輪(用途：化工、食品類等...)。
適用於高低黏度之液體以及液體內含有軟質固形物
Non friction type two leaf type Rotary Lobe Pumps。
(Uses: chemical, food, etc.)

Suitable for high and low viscosity liquid and Soft solid in liquid
(例：水果、蔬菜、魚肉、乳膠等)均可使用。

如有較大固形物，可直接加裝漏斗作為吸入口使用。
(ex : fruits, vegetables, fish, latex, etc.) Can use .

If there is a larger solid , can be directly installed funnel and use as a
suction port .

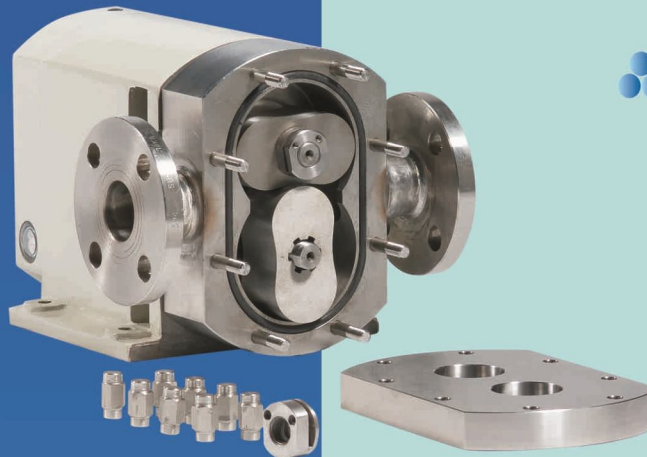

二翼四瓣式形輪

Two wing four flap type Rotary Lobe Pumps

非摩擦式二翼四瓣式形輪(用途：化工、食品類等...)。
適用低黏度液體高效率輸送，低攪動、剪力，降低產品
輸送物的損傷、衛生潔淨。

Non friction type two wing four flap type Rotary Lobe Pumps。
(Uses: chemical, food, etc.)

Suitable for low viscosity liquid with high efficiency , Low agitation
、shear force , Reduce the damage of the products ,
Clean and sanitary . Positive reversal can choose to use .

正逆轉均可選擇使用。

Positive reversal can choose to use .



高強度重負荷設計，適合化工、食品高粘度 輸送耐溫最高可達200°C，粘度1000000CPS

High-strength heavy-duty design, Suitable for chemical, food and transport high-viscosity, Temperature up to 200 °C, Viscosity 1000000CPS.

葉瓣形輪Rotary Lobe Pumps特點

Lobe-shaped wheel Rotary Lobe Pumps feature

非摩擦式，高精度瓣輪，無金屬摩擦之慮

Non friction type, High precision gear, No metal friction.

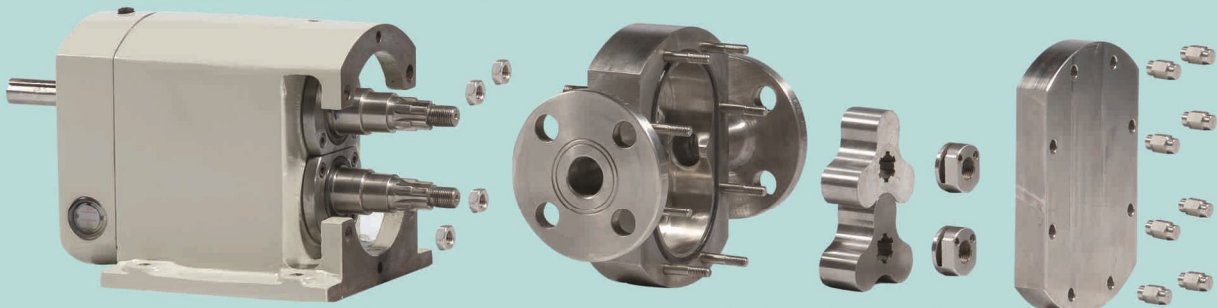

※動力負荷，扭轉由齒輪箱主副軸驅動，葉瓣輪無摩擦之慮。

Power load, Rotationally driven by a spindle countershaft gearbox.

※不同液體可選擇不同的葉瓣輪(每種規格可隨意互換)。

Different liquids choose a different vane wheel. (Each specification can be freely interchangeable)

※Lobe Pumps可輸送內含軟質的顆粒及固形物。

Lobe Pumps deliverable containing soft particles and solids.

※每轉流量、流速穩定、低脈動、液體不起泡，運轉時安靜無噪音。

Flow per revolution, Flow rate stable, Low pulsation, Liquid non-foaming, No noise during operation.

※拆裝清洗方便(見上圖)。

Easy disassembly cleaning (Pictured above).

※泵浦輸送液本體與驅動齒輪箱隔離、輸送液無污染之慮。

Transmission fluid pump body and the drive gear box isolation, Transport liquid is not contaminated place.

※不同液體特有精心設計適用之軸封。

Different liquids unique seal designed applicable.

※最高粘度：1000000CPS以內。

Applicable Viscosity: less than 1000000 CPS.

※材質：不銹鋼304#、316#、410#及碳鋼。

Material: Stainless steel 304 #, 316 #, 410 # and carbon steel.



輸送食品液體：

特別設計泵腔內無死角間隙，固定葉瓣輪螺母加裝一條O型環，防止液體滲透進入軸心螺紋內，而產生發酵作用，污染輸送液體。

Liquid food delivery:

Specially designed pump body no dead space, Fixed vane wheel nut installation of an O-ring, Preventing liquid penetration into the axis of the inner thread, Producing fermentation, Pollution transport liquid.



為了方便正逆轉兩用而防止鎖緊葉瓣輪的螺母鬆脫，特精加工兩支螺栓固定能使鎖緊葉瓣輪的螺母確保正逆轉時不鬆脫。

In order to facilitate a positive reversal of dual-use, Prevent the locking wheel nut loose, Special finishing two bolts fixed, The locking wheel nut to ensure that no loose when forward and reverse.

光星RL-3系列泵浦尺寸圖

RL-3 series pump dimension drawing

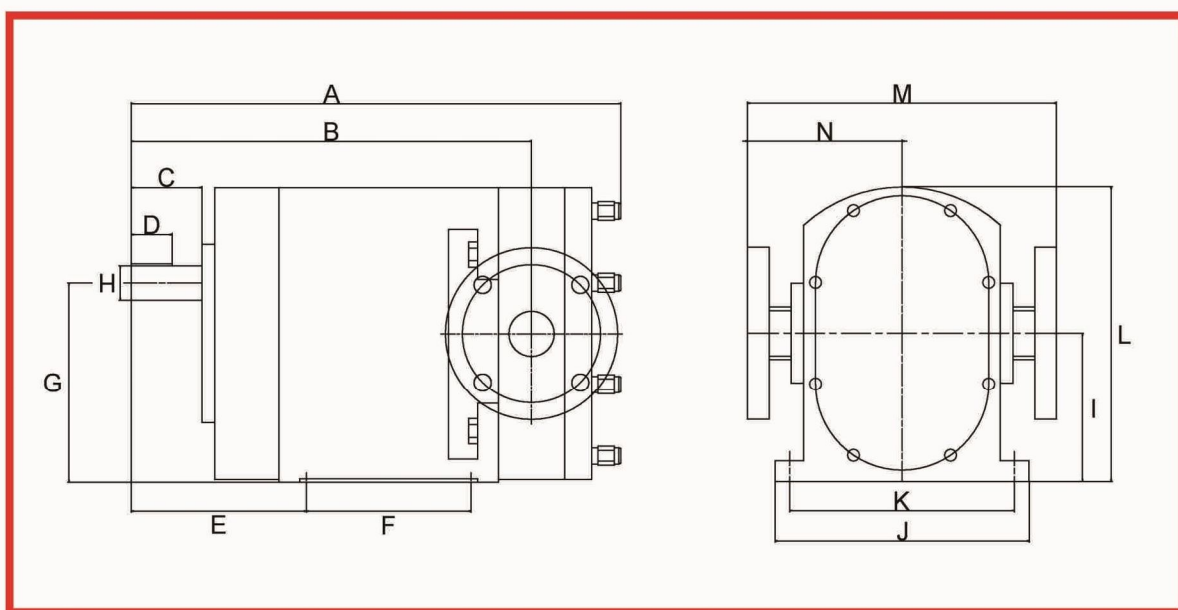

| 泵型式 TYPE | 口徑 BORE | A | B | C | D | E | F | G | H DIA | I | J | K | L | M | N |
|-------------|------------|-----|-------|----|----|-----|-----|-------|----------|-----|-----|-----|-------|-----|-------|
| RL-301 | 1" | 406 | 333 | 64 | 60 | 154 | 125 | 129 | 20 | 99 | 182 | 160 | 195 | 202 | 101 |
| RL-302 | 1 1/2" | 437 | 347 | 64 | 60 | 156 | 130 | 158 | 25 | 120 | 236 | 190 | 216 | 240 | 120 |
| RL-303 | 2" | 504 | 408 | 70 | 65 | 177 | 167 | 188.5 | 32 | 142 | 254 | 226 | 280.5 | 282 | 141 |
| RL-303L | 2" | 508 | 441.5 | 78 | 70 | 184 | 200 | 220 | 40 | 164 | 280 | 250 | 325 | 329 | 164.5 |
| RL-304 | 3" | 582 | 457 | 82 | 77 | 202 | 197 | 245.5 | 45 | 183 | 310 | 278 | 363 | 358 | 179 |
| RL-305 | 4" | 646 | 610 | 80 | 75 | 221 | 212 | 314.5 | 50 | 232 | 372 | 336 | 475 | 414 | 207 |

台灣總公司:

 光星機械股份有限公司

KUANG HSING MACHINERY CO.,LTD.

台南市永康區中正南路306巷10號

電話:(06)2534611~3 傳真:(06)2536807

公司網址:<http://www.kuang-hisng.com.tw>

電子郵件:kuang.hisng@msa.hinet.net

中國大陸廠:

 尚億新型鍋爐(江陰)有限公司

江蘇省江陰市華士鎮陸橋陸東大街158號

電話:0510-86376191~2傳真:0510-86376193

公司網址:www.shangyiboiler.cn.alibaba.com

電子郵件:shangyiboilers@163.com

深圳光星:

廣東省深圳市龍崗鎮洪圍新村22號

電話:0755-84853750傳真:0755-84852752